

# PAM500

## Panic Alert Unit

### Installation Instructions



#### General

PAM500 is a panic alert/nurse call unit, intended for use in the FORCE security system.

The unit provides an audible and visual warning when an emergency button is pressed (external to the module), and opens a zone in the alarm system.

Pressing the release button (external to the unit) stops the alarm and closes the zone in the alarm system.

#### Circuit description:

##### General

#	Description
1	Terminal Blocks - Inputs
2	Terminal Blocks - Outputs
3	Switches for buzzer and lighting control
4	Alert Light

##### Switches

Notes: switches 2-4 for buzzer

Switch 4 – for light

	Flashing light Refer to switch 1 only
	Constant lighting Refer to switch 1 only
	Max buzzer volume Switch 2-4
	Medium buzzer Switch 2-4
	Min buzzer volume Switch 2-4
	Buzzer is off Switch 2-4

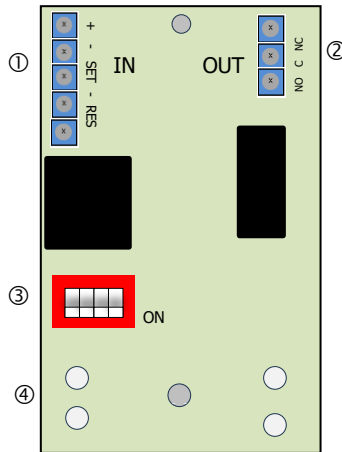

##### Terminal Block - Inputs

Name	Description
+	Input Voltage +12VDC
-	Input Voltage return
SET	Panic Button Input
-	Common for Panic and Release buttons
RES	Release Button Input

##### Terminal Block - Output

Connect to Alarm System zone

NC	Relay NC terminal
C	Relay Common terminal
NO	Relay NO Terminal

#### Specification

- Panic input: dry contact, NO
- Release input: dry contact, NO
- Operating voltage range: 10-15VDC
- Current consumption (during alarm): 30mA
- Dimensions: 120 x 70 x 50 mm
- Weight: 100 g
- Temperature range: -10°C to +55°C

#### The contents of the product packaging

- PAM500 distress alert unit
- Two installation screws + dowels
- Installation page

## How to install and connect the PAM500

See the connection diagram in the following Figure.

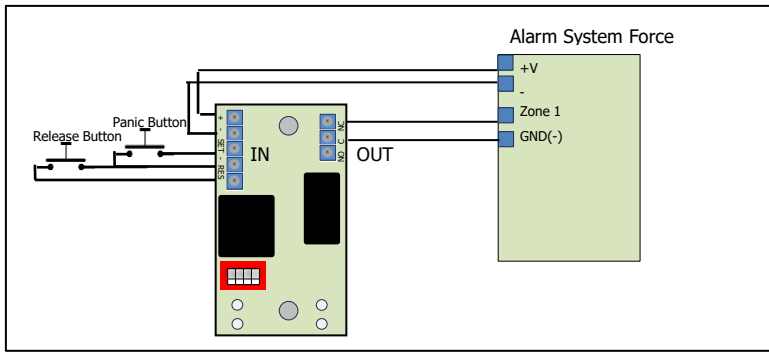

The screws and dowel kit supplied with the product must be used

1. Remove the two front cover parts from the base.
2. Drill two holes in the wall according to the corner holes of the base (#1 in the Figure on the right) and insert the dowels.
3. Thread the wires intended for connection through the two holes in the base (no. 2 in the Figure on the right).
4. Assemble the red part of the cover (bottom) on top of the base and fasten them together to the wall with one of the screws.
5. Connect the wires coming from the panic button to the SET input and ground.
6. Connect the wires coming from the release button to the RES input and ground.
7. Connect the NC and C outputs to a suitable zone input on the alarm system.
8. Assemble the white part of the cover to the base and fasten with the second screw.

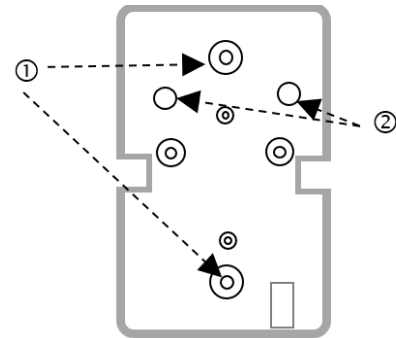

Both buttons, panic and release, must be of the Normally Open type, meaning they short the contacts when pressed.

Consult PIMA for suitable in-stock buttons.

## Installation options

See Figure 2 for the different installation options:

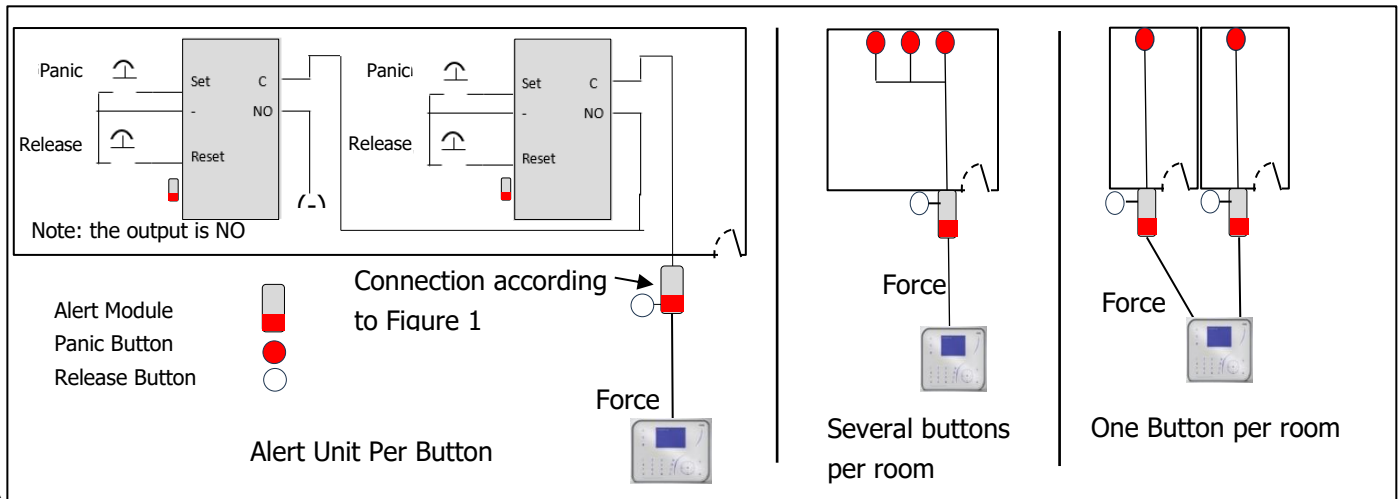

Figure 2: Installation Options

---

Note: since the buttons are of the Normally Open type, it is possible to connect them in parallel; For example, it is possible to connect several release buttons simultaneously to the input of one alarm unit.

## Force system programming and operation

Each zone in the Force system that connects to the alarm unit must be set as follows:

- NC
- 24 hours

After receiving an alarm indication on the keypad, the indication must be deleted by holding down the quit key ↵.

If you want an audible warning with a higher volume than the buzzer of the security guard/nurse, you can connect a buzzer/siren to the relay output of the alarm system.

## Alarm Controller Software

When connected to the Force system, the alarms appear on the keypad.

You can connect the Force system to a computer with software to display the alarms and manage them conveniently on the computer screen.

Consult with PIMA on this matter.

## Ordering Information

PAM500: P/N 8160004

### Limited Warranty

PIMA Electronic Systems Ltd. does not represent that its product may not be compromised and/or circumvented, or that the Product will prevent any death, personal and/or bodily injury and/or damage to property resulting from burglary, robbery, fire or otherwise, or that the Product will in all cases provide adequate warning or protection. The User understands that properly installed and maintained equipment may only reduce the risk of events such as burglary, robbery, and fire without warning, but it is not insurance or a guarantee that such will not occur or that there will be no death, personal damage and/or damage to property as a result.

Read this guide in its entirety before attempting to program or operate your system. Should you misunderstand any part of this guide, please contact the supplier or installer of this system.

Produced by:

PIMA Electronic Systems Ltd.

www.pima-alarms.com

5, Hatzoref Street, Holon 5885633, Israel

Tel: +972.3.6506411

Email: support@pima-alarms.com



Link to updated literature